

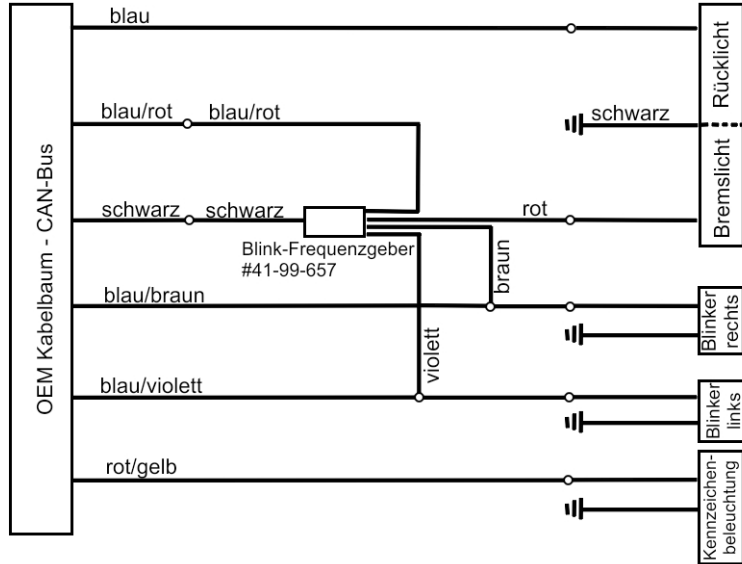

BLINK-FREQUENZGEBER FÜR LED-BLINKER & RÜCKLICHTER

Anschlusschema CAN-Bus-Modelle:



Unbedingt das Bremslicht, wie im Schema anschließen, um Fehlfunktionen des ABS zu vermeiden!

Anschlusschema Modelle ohne CAN-Bus:

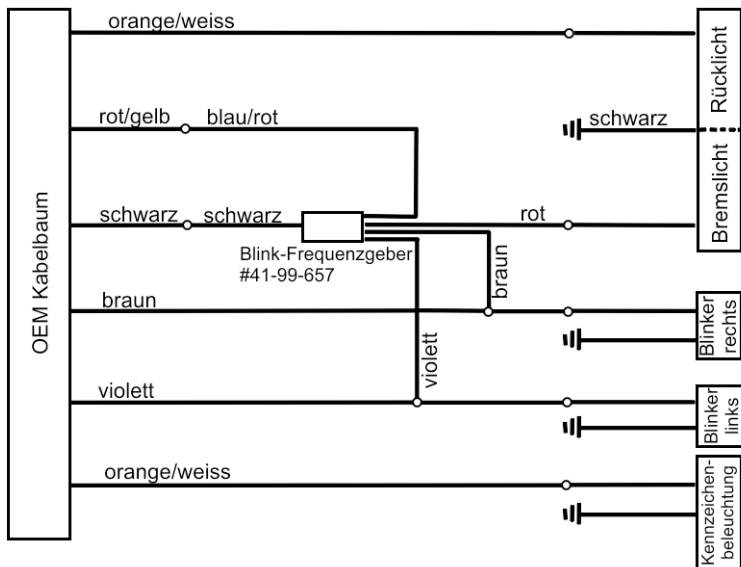

TURN SIGNAL LOAD EQUALIZER FOR LED TURN SIGNALS & TAILLIGHTS

Wiring scheme CAN bus types:

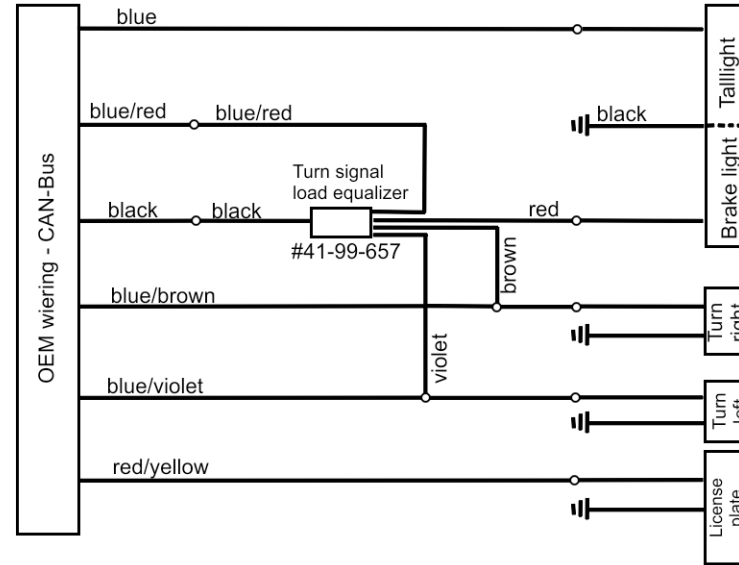

Take care to connect the brake light as shown in the scheme to prevent malfunction of ABS!

Wiring scheme types without CAN bus:

